

THIS DRAWING IS UNPUBLISHED. RELEASED FOR PUBLICATION, 19
 © COPYRIGHT 19 BY AMP INCORPORATED, HARRISBURG, PA. ALL INTERNATIONAL RIGHTS RESERVED. AMP PRODUCTS MAY BE COVERED BY U.S. AND FOREIGN PATENTS AND/OR PATENTS PENDING.

REVISIONS				DATE	APPROVED
P	F	ZONE	LTR	DESCRIPTION	
				F. OBS:-2;EC'0210-0416-96.	2/10/86 DS MH

1 MATERIAL: POLYPHENYLENE, BLACK.

2 ALL DIMENSIONS ARE MAXIMUM UNLESS OTHERWISE SPECIFIED.

3 ONE KIT PER POLY BAG.

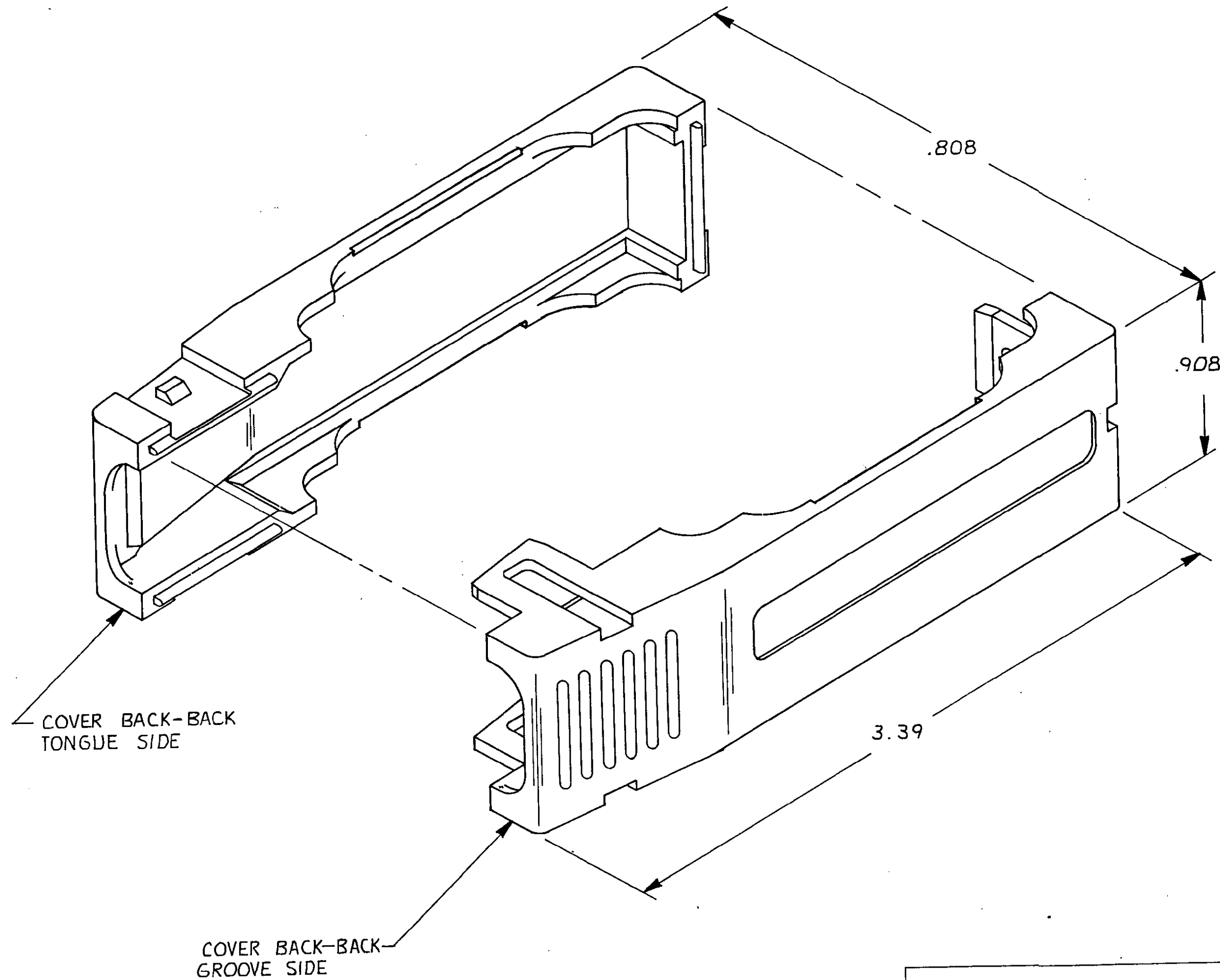

554831

3	.300 - .375	554831-1
PACKAGED	CABLE RANGE	PART NO

UNLESS OTHERWISE SPECIFIED DIMENSIONS ARE IN INCHES. TOLERANCES ON: DECIMALS ± = ANGLES ± =	CONTRACT NO	AMP AMP INCORPORATED Harrisburg, Pa. 17105		
	DR B. SIMPSON 6-24-85	NAME		
	CHK S. FOX 6-27-85	COVER KIT, BACK/BACK, 24-POSITION, CHAMP		
	APPD B. HUTCHINS 6/27/85	SIZE	FSCM NO	DRAWING NO
FINISH	OTHER APPD	C	00779	554831
		SCALE 2:1	SHEET 1 OF 1	

CUSTOMER DRAWING